



Pre-service and in-service inspections of welds of the EPR reactor

Sosnowiec

October 17th, 2018



SUMMARY OF PRESENTATION

Part I: EDF at a glance

Part II: The EPR reactor and its scope of supply & opportunities

Part III: Localization & Qualification process

Part IV: PSI/ISI of the main welds of the EPR reactor

Part V: Conclusions

SUMMARY OF PRESENTATION

Part I: EDF at a glance

Part II: The EPR reactor and its scope of supply & opportunities

Part III: Localization & Qualification process

Part IV: PSI/ISI of the main welds of the EPR reactor

Part V: Conclusions

EDF GROUP AT A GLANCE

Efficient & responsible
electricity company, champion
of the low-carbon growth

69.6
billion euros
in annual revenue



580.8 TWh
EDF Group's
electricity generation

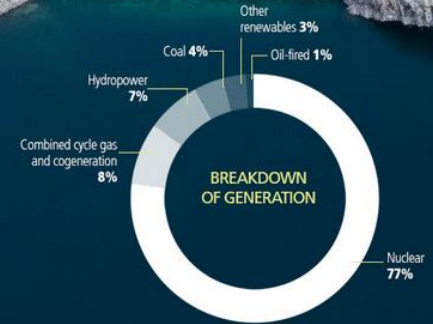

152,033
employees worldwide

35.1
million clients
worldwide



611
million euros
in R&D budget



87%
of electricity CO₂ free*



* Direct emissions, excluding the life cycle analysis of generating plant and fuel.

**EDF produces around 22% of the European Union's electricity,
primarily from nuclear power**

EDF, THE VENDOR OF THE FRENCH NUCLEAR TECHNOLOGY

6 EPR REACTORS UNDER CONSTRUCTION



Flamanville 3



Olkiluoto 3



Taishan 1&2



Hinkley Point 1&2



SUMMARY OF PRESENTATION

Part I: EDF at a glance

Part II: The EPR reactor and its scope of supply & opportunities

Part III: Localization & Qualification process

Part IV: PSI/ISI of the main welds of the EPR reactor

Part V: Conclusions

THE EPR REACTOR

1,650 MWe PWR



- Generation III+ PWR
- High power output (1,650 MWe)
- Evolutionary design (Konvoi / N4)
- Low global power generation costs
 - Fuel consumption reduced by up to 15%
 - 60 years of operation
 - Improved flexibility to reduce OPEX
- Maximized benefit from size effect
- Minimal environmental impact
- MOX Fuel capability
- Reactor being designed in collaboration with utilities and safety authorities
- EUR criteria compliant
- An outstanding safety level...

... ACHIEVED TODAY THROUGH THE EPR REACTOR

Reduce the probability of a severe accident with core meltdown

Physical separation, diversity, and redundancy of critical components



Protect population and environment in case of severe accident

Confined corium and radioactive products in the reactor ("core catcher")



Protect against malevolent act (e.g. airplane crash)

High structural resistance

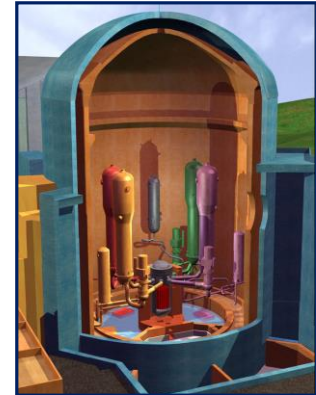

EPR REACTORS - THE FULL SCOPE OF SUPPLY

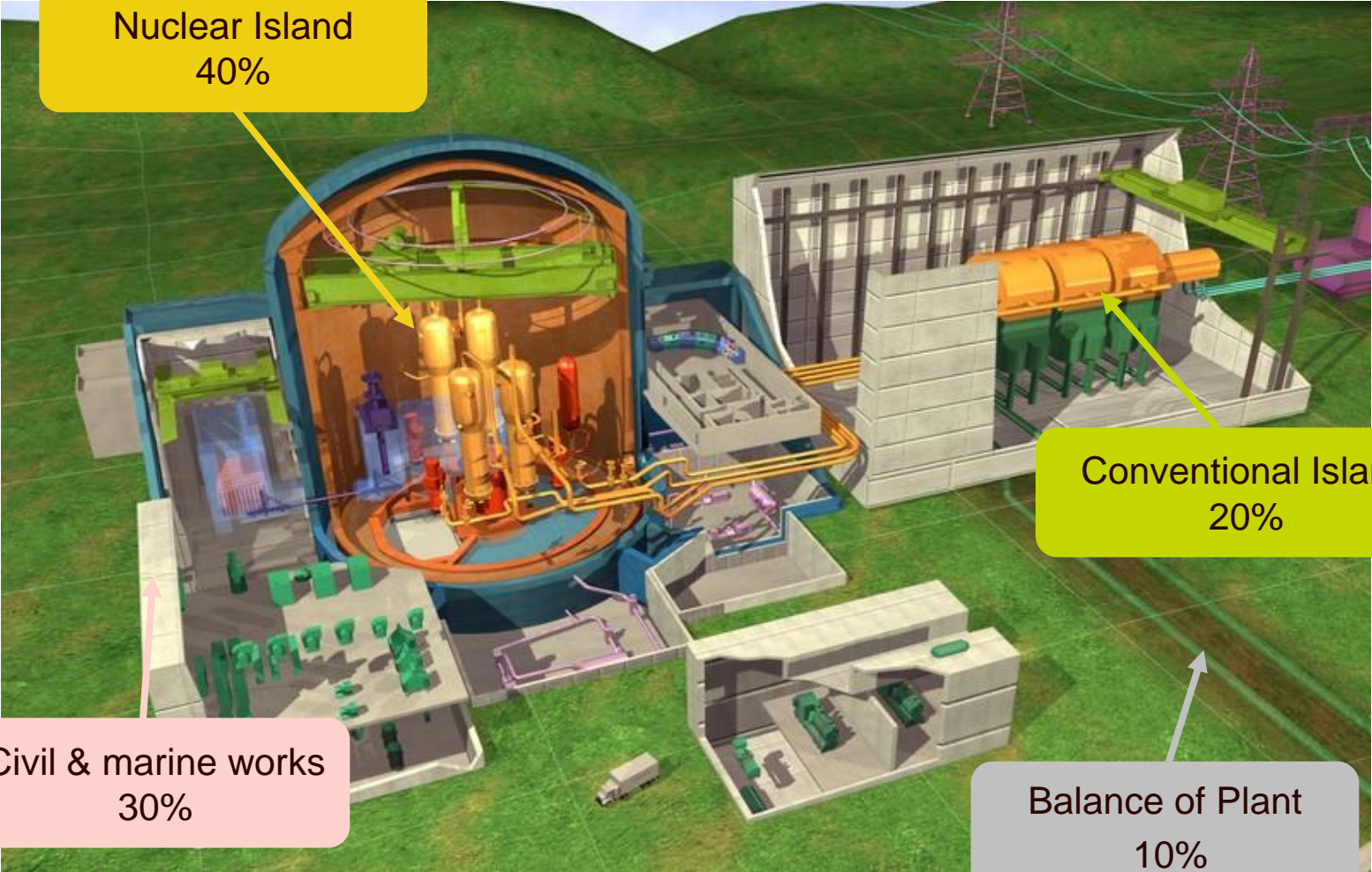

EPR REACTORS - THE FULL SCOPE OF SUPPLY

Nuclear Island (NI) - Conventional Island (CI) - Balance of plant (BOP)



- ◆ Project Management
- ◆ Engineering
- ◆ Equipment supply
- ◆ Installation
- ◆ Civil works
- ◆ Commissioning



- ◆ Site preparation & infrastructure (Clearance / leveling & roads, drainage, water...)
- ◆ Site camp
- ◆ Marine works / Cooling Towers
- ◆ Buildings

Nuclear Island - a combination of “nuclear safety” and “non-safety” equipment and systems
CI and BOP are similar to the type of works found in a conventional power plants
and in the oil & gas industry

EPR REACTORS - PROCUREMENT NUCLEAR ISLAND (NI)

Mechanical Equipment

- 150 Heat exchangers
- 180 pressure vessels & tanks
- 500 pumps/compressors/filters
- 12 000 valves
- 1800 t of Large & Small bore piping with associated supports (1000t)



Electrical Equipment

- Cable trays
- 3000km of cables
- LV/HV switchboards
- Transformers
- 6 Emergency Diesels Generators



HVAC Equipment

- Total need of 860 000 m3/h
- Ductwork
- Air handling units
- Chillers
- Fan, Damper, filters, coils....

Handling Equipment

- Monorails, slewing cranes 2 to 20 T
- 1 Polar crane & 2 Gantry cranes



A WIDE SCOPE OF OPPORTUNITIES...

CONVENTIONAL ISLAND (CI)/BALANCE OF PLANT (BOP)

- ▶ The CI/BOP is composed of a wide range of buildings with different functions.
- ▶ Most of the CI/BOP Structures, Systems and Components follow conventional codes and standards

Conventional Island (CI)

- ▶ The CI corresponds to all SSC directly involved in the electricity production and transmission to the grid:
 - ◆ Turbine Hall,
 - ◆ Electrical Distribution Building,
 - ◆ Power Transmission Platform

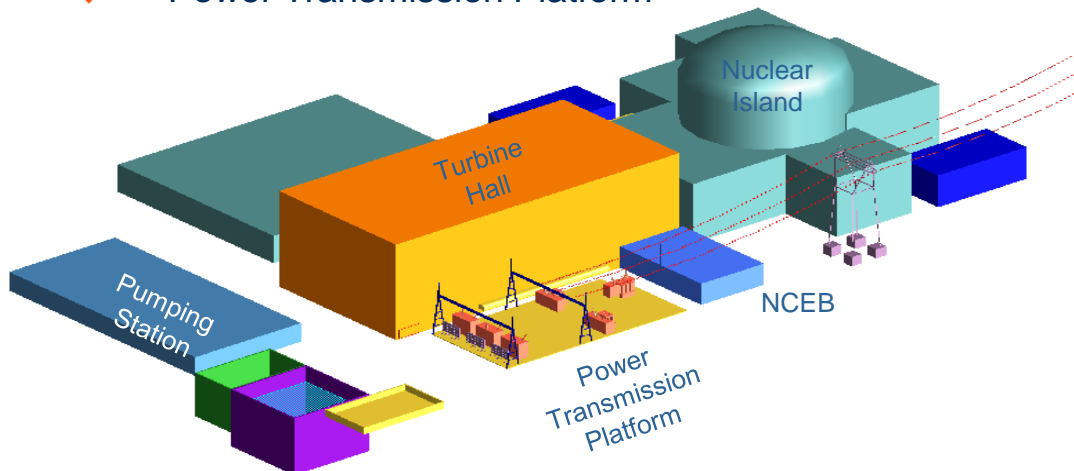

Balance of Plant (BOP)

- ▶ The BOP corresponds to all support SSC necessary for the NPP operation :
 - ◆ Pumping Station/Outfall Building,
 - ◆ Marine Works,
 - ◆ Galleries,
 - ◆ Auxiliary boilers,
 - ◆ Demineralization plant + tanks,
 - ◆ Gas storage (CO₂, N₂, Hydrogen...),
 - ◆ Chlorination building

SUMMARY OF PRESENTATION

Part I: EDF at a glance

Part II: The EPR reactor and its scope of supply & opportunities

Part III: Localization & Qualification process

Part IV: PSI/ISI of the main welds of the EPR reactor

Part V: Conclusions

LOCALIZATION AND QUALIFICATION PROCESS

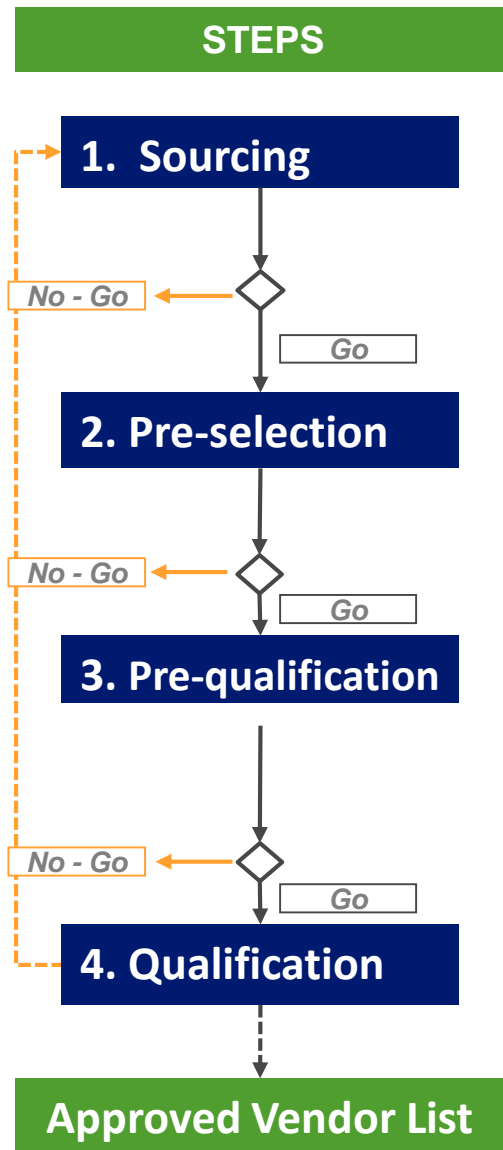

1. Sourcing

- Establish the master supplier list
- Initiate first contact visits
- Send Request For Interest (RFI)

2. Pre-selection

- Preselect suppliers according to RFI feedback analysis
- Visit Suppliers for pre-assessment (quality management, design, manufacturing, etc.)

3. Pre-qualification

- Define development plan and follow-up
- Carry out product or process qualification tests as necessary
- Send a blank RFQ for detailed technical assessment

4. Qualification

- Approve supplier once qualification is satisfactory before the contract is signed (Approved Vendor List)

POLISH SUPPLIERS HAVE WORKED FOR THE EPR TECHNOLOGY

- ▶ 25 Polish suppliers have worked on the EPRs under construction,
- ▶ Huge involvement of Polish personnel in **Olkiluoto 3** and Flamanville 3 projects.

ELEKTROBUDOWA SA:

Installation of all electrical and I&C equipment at OL3

- All electrical and I&C Equipment at OL3 EPR™ project
- Nuclear Installation Contracts for other Projects
- Several subcontractors, mainly for cable pulling



Polish industry has gained significant competences in the nuclear sector with the EPR projects

A WIDE SCOPE OF OPPORTUNITIES... DURING PLANT OPERATION

2 EPR units

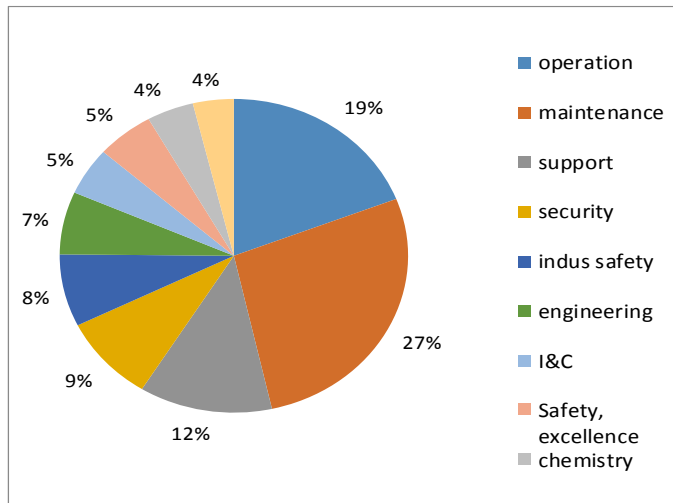

Sub-contracted competencies

- ▶ Nuclear logistics and services
- ▶ Electrical / I&C maintenance
- ▶ Non Destructive Testing
- ▶ Piping, welding
- ▶ Heat insulation
- ▶ Turbo generator maintenance
- ▶ Valves, Pumps maintenance

Subcontractors for Operation & Maintenance

- ▶ **100 to 200 permanent contractors** during operation phase (for 2 units)
- ▶ **300 to 1,000 additional contractors** during unit outages (once a year)

The construction of an EPR creates direct business opportunities for maintenance over 60 years

SUMMARY OF PRESENTATION

Part I: EDF at a glance

Part II: The EPR reactor and its scope of supply & opportunities

Part III: Localization & Qualification process

Part IV: PSI/ISI of the main welds of the EPR reactor

Part V: Conclusions

THE RSE-M CODE

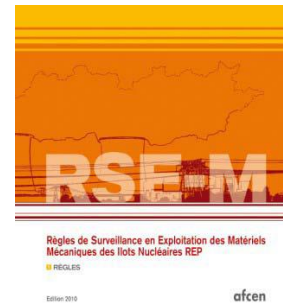
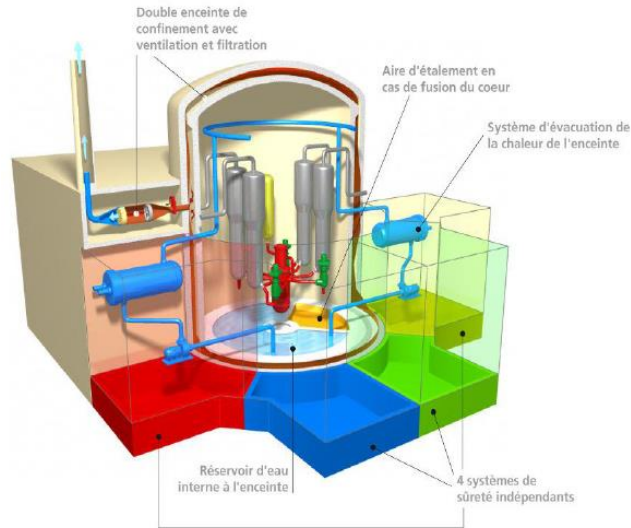

The RSE-M code defines general and specific In-Service-Inspection rules for:

- ▶ Class 1 pressure components (Main Primary and Secondary systems)
- ▶ Class 2 or 3 pressure components
- ▶ Conventional pressure components

The last up to date edition “RSEM 2017” includes the PSI program for EPR:

- ▶ Appendix 3.1.I: Inspection tables for class 1 pressure components.
- ▶ The scope is currently the inspection program for the French EPR unit: Flamanville 3.

PRE-SERVICE INSPECTION AND IN-SERVICE INSPECTION



DEFINITION & OBJECTIVES:

- ▶ The main objective of the NDE is to detect damages / degradations in relation with the operated plant life. It is composed of two parts

The pre-service inspection (PSI):

- ▶ The PSI is a complete inspection of the main primary and secondary systems (class 1 equipment).
- ▶ The PSI is carried out before operating the NPP (before the first core loading).
- ▶ The PSI is performed with the same (qualified) NDE planned for the In Service Inspection.
- ▶ The PSI is a reliable NDE reference for the future ISI plant life (zero point), a verification of the NDE capability (accessibility..) and an ultimate examination before operating.

The in-service inspection (ISI):

- ▶ The ISI is carried out during outages of the NPP.
- ▶ The ISI is performed periodically, with a periodicity defined by the plant operator
- ▶ The objective of the ISI is to ensure there is no evolution of NDE indications during the operation of the plant

THE APPROACH TO DEFINING THE PSI/ISI PROGRAM

PSI PROGRAM DEVELOPMENT

RSE-M Appendix 3.1.1 proposes a PSI/ISI program for class 1 components based on EDF fleet and international experiences.

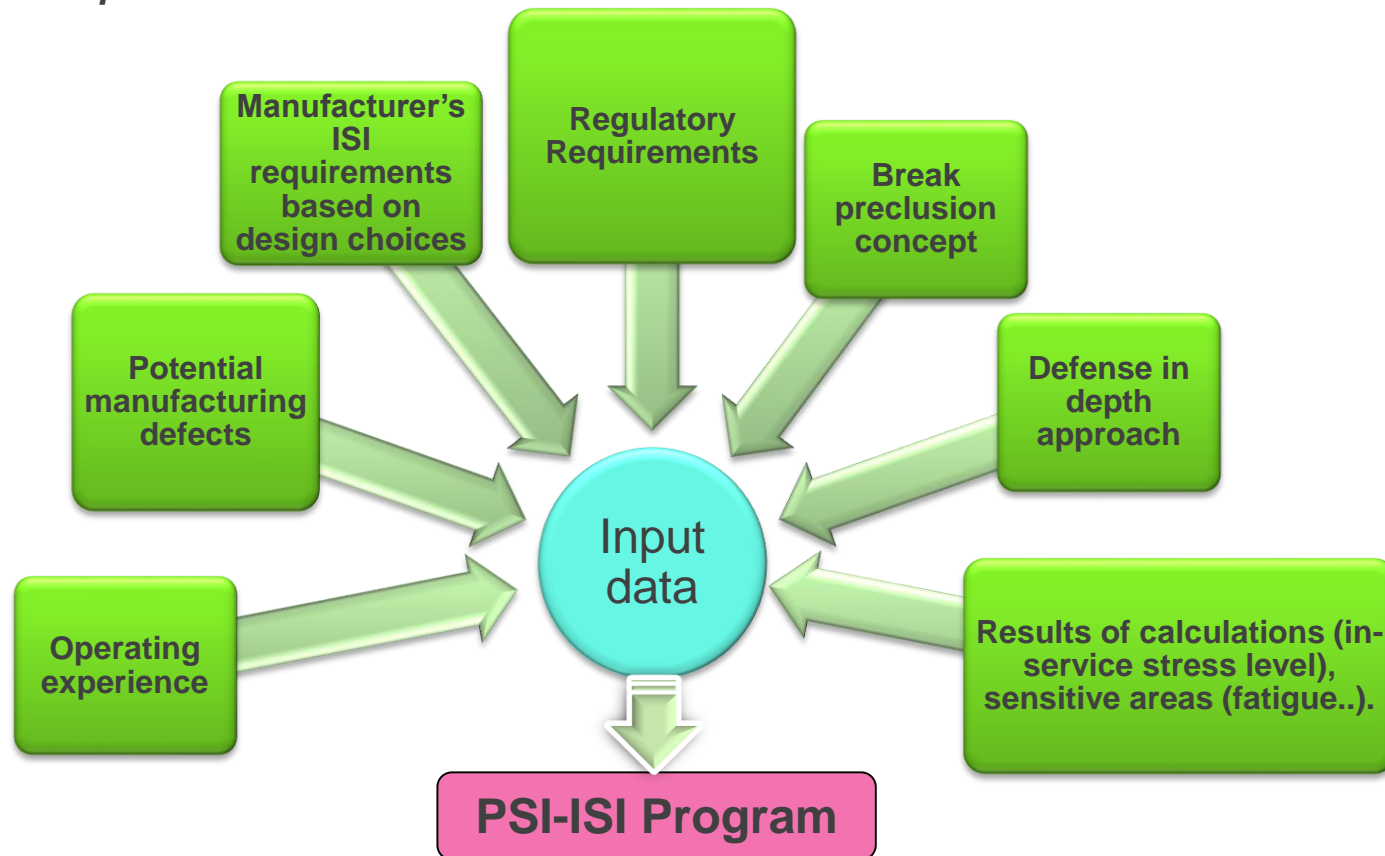

This program is in accordance with the security policy with a significant promotion of ultrasonic methods instead of radiography.

BALANCE OF EXAMINATION METHODS

Equipment system	Nb of parts (zone type) to be inspected
Reactor vessel	7
Reactor vessel closer head	5
Closure head control rod drive mechanism housings	4
Vessel closure head bolts	3
Steam generator: primary side and tube bundles	14
Pressurizer	22
Reactor coolant pump	5
Main coolant lines (reactor coolant loops and pressurizer surge line)	8
MPS valves	1
MPS piping (auxiliary piping)	7
Steam generator: secondary side	14
MSS valves	1
MSS piping	21
TOTAL	112

Methods	Nb
Visual Test	23
Remote Visual Test	11
Ultrasonic	55
Radiography	12
Eddy Currents	5
Penetrant testing	15
Magnetic particules testing	3
Acoustic emission	5
TOTAL Nota: A few parts are inspected with 2 methods	129

Examination methods

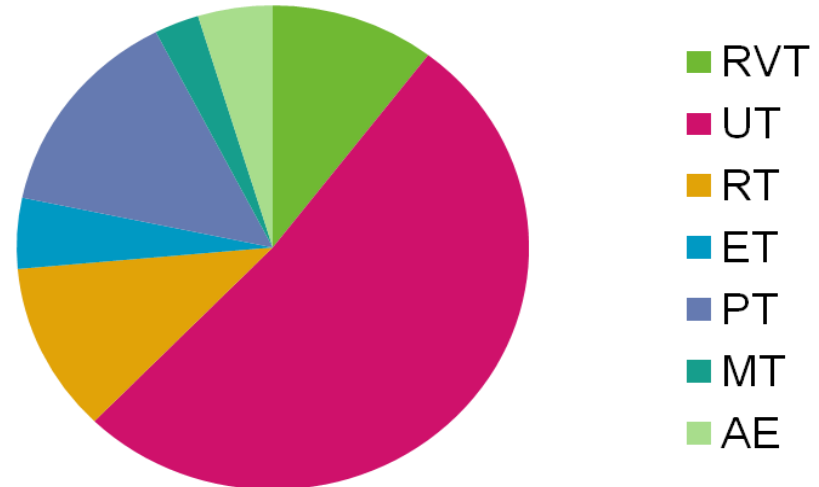

→ A large part for UT techniques

QUALIFICATION OF EXAMINATION TECHNIQUES

In France, the French Ministerial Order of the 10th November 1999 regulates the In Service Inspection of the main primary and the main secondary systems of pressurised water NPP:

- It requires the certification of the NDE operators by RTPO
- It requires the qualification of any NDE process before its use on a NPP.
- The qualification is pronounced by an independent qualification body, the « Qualification Commission » (NDE experts) accredited according to the ISO 17020-type B (by COFRAQ since 2002).

The French qualification process (according the RSEM code, ENIQ principles) is a performance demonstration of an NDE application. This process has been approved by the French Regulatory Authorities.

INSPECTION OF THE REACTOR PRESSURE VESSEL

Reactor vessel body – B 3200.1 EPR Table:

Parts to be inspected	Examination method
Circumferential welds in core region (item 2)	Ultrasonic examination (underwater) B4210

B4000 Chapter: Objectives and techniques of examinations performed during inspections. (extracts below)

B4210-1: Aims of the examination:

- As part of In-depth defense, the aim of volumetric examination of welds

B4210-2 : Zones:

For each weld, the zone to be examined comprises the volume of the deposited metal plus the adjacent base metal across a distance to be specified by the Licensee, which shall include the heat –affected zone. The zone to be examined shall not include inner wall cladding

B4210-3 Examination technique, recording threshold and characterization objectives:

The techniques uses ultrasound waves focused under water to limit the effect of the cladding surface...

Scanning is performed circumferentially and longitudinally with respect to the weld axis.

The recording threshold of indications shall comprise the following:

- an amplitude criterion, set at 25% (-12dB) of the signal amplitude produced by the 2 mm diameter side-drilled holes in the reference block, which is taken as the reference for the weld section examined,
- an indication length criterion, if required by the Licensee.

.....

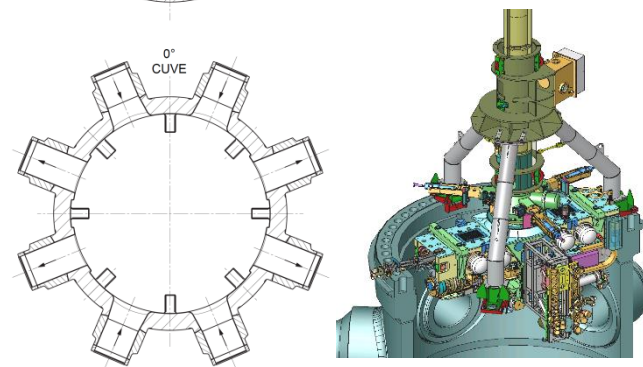
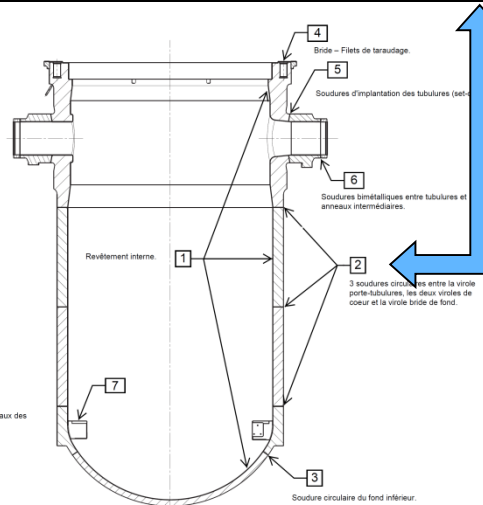

Appendix 4.4: French Licensee's procedure: Description of the NDE techniques / equipment .

In-Service Inspection Machine

INSPECTION OF THE MAIN COOLANT LINES

Main coolant lines & surge line – B 3200.9 EPR Table:

Parts to be inspected	Examination method
Homogeneous welds (item 1,2 and 3)	Ultrasonic examination B4800

B4000 Chapter: Objectives and techniques of examinations performed during inspections.
(extracts below)

B4810-1: Aims of the examination:

- As part of In-depth defense, the aim of volumetric examination of welds and adjacent areas is to detect any possible defects which might be detrimental to the integrity of the structure.....

B4810-2 : Zones:

For each weld, the zone to be examined comprises the volume of the deposited metal plus the adjacent base metal across a distance to be specified by the Licensee, which shall include the heat-affected zone.....

B4810-3 Examination technique, recording threshold and characterization objectives:

A- Ultrasonic examination

The technique uses ultrasound waves with contact (automated equipment) from outside the piping...
Scanning takes place perpendicular to the weld axis.....

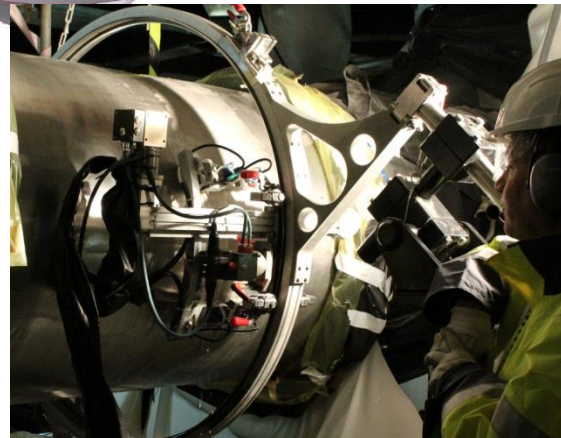
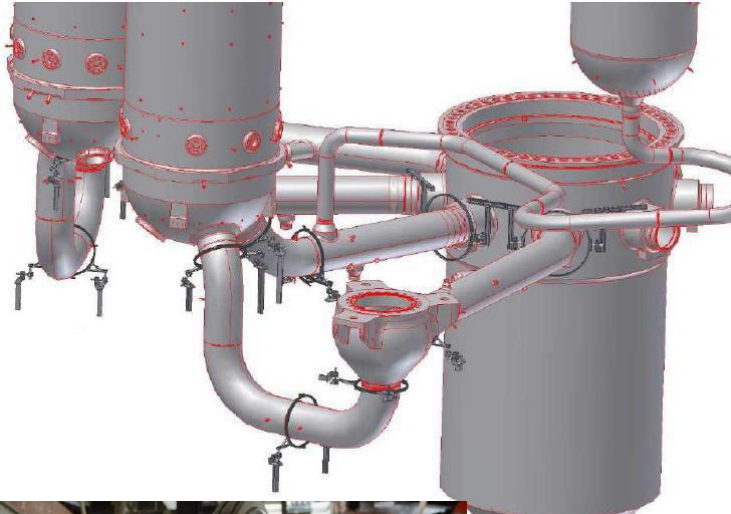

INSPECTION OF THE PRESSURIZER

Pressurizer – B 3200.7 EPR Table:

Parts to be inspected	Examination method
Weld to position the surge nozzle on the bottom head (item 12)	Radiography B4640

B4000 Chapter: Objectives and techniques of examinations performed during inspections.
(extracts below)

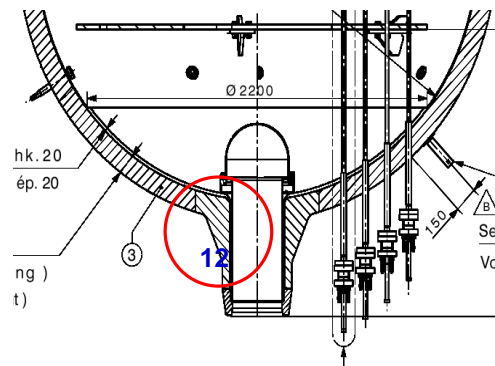

B4640-1: Aims of the examination:
- As part of In-depth defense, the aim of volumetric examination of welds and adjacent areas is to detect any possible defects which might be detrimental to the integrity of the structure.....

B4640-2 : Zones:
The zone to be examined comprises the volume of the deposited metal plus the adjacent base metal across a distance to be specified by the Licensee, which shall include the heat-affected zone.....

B4640-3 Examination technique, recording threshold and characterization objectives:

The examination technique is based on a panoramic exposure to a radiation source centered inside the pressurizer. The usage conditions shall be those specified in RCCM MC 3300....
The recording threshold applies to indications...

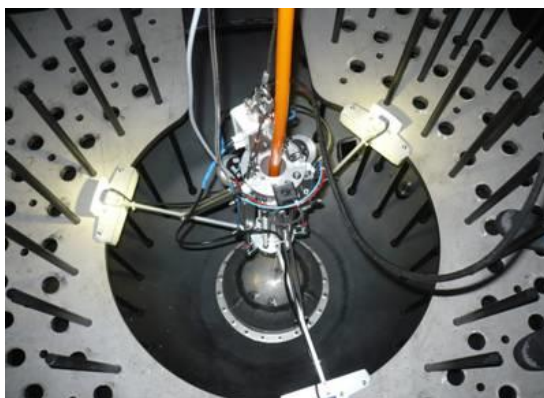

INSPECTION OF MAIN STEAM SYSTEM PIPING

MSS piping – B 3200.14 EPR Table:

Parts to be inspected	Examination method
Circumferential welds	Ultrasonic examination (B4850)

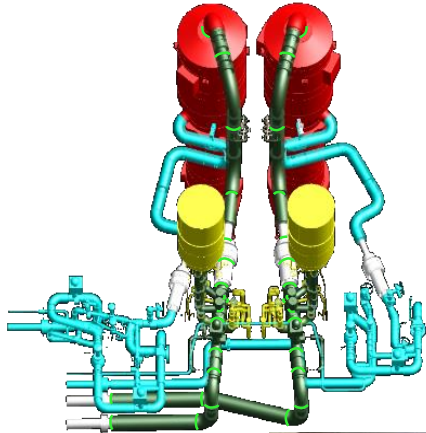

B4000 Chapter: Objectives and techniques of examinations performed during inspections.
(extracts below)

B4850-1: Aims of the examination:

-- As part of In-depth defense, the aim of volumetric examination of welds and adjacent areas is to detect any possible defects which might be detrimental to the integrity of the structure.....

B4850-2 : Zones:

For each weld, the zone to be examined comprises the volume of the deposited metal plus the adjacent base metal across a distance to be specified by the Licensee, which shall include the heat –affected zone.....

B4850-3 Examination technique, recording threshold and characterization objectives:

A-Ultrasonic examination

The techniques uses contact ultrasound from the external wall of the pipes. This technique is automated for girth welds for connection to the RB penetration side walls. Scanning takes places perpendicular to the weld axis. The recording threshold of indications shall be as specified in A 4221.4.

LEAK TIGHTNESS INSPECTION OF THE MAIN PRIMARY SYSTEM

B 3200.3 -4-7 EPR Tables: leaktightness test (during hydraulic proof test)

Parts to be inspected	Examination method
Vessel closure head: weld between adapter flange and adapter (item 4)	Acoustic emission B4910
CRDM housings	Acoustic emission B4910
Pressurizer: welds between heater wells and bottom head (item 7A) - flange assemblies (item 7 B)	Acoustic emission B4910

B4000 Chapter: Objectives and techniques of examinations performed during inspections.
(extracts below)

B4910-1: Aims of the examination:

The aim of this global examination is to detect any possible water leaks of joints (welds, flange assembly) occurring during the hydraulic proof test of the MPS.

B4910-2 : Zones:

The joints to be examined (if existing) are:

- Closure vessel head:.....
- CRDM housings welds.....
- Pressurizer.....
- Vessel

B4910-3 Examination technique, recording threshold and characterization objectives:

The examination technique uses acoustic emission as specified in A4280 during a pressure level of the hydraulic proof test

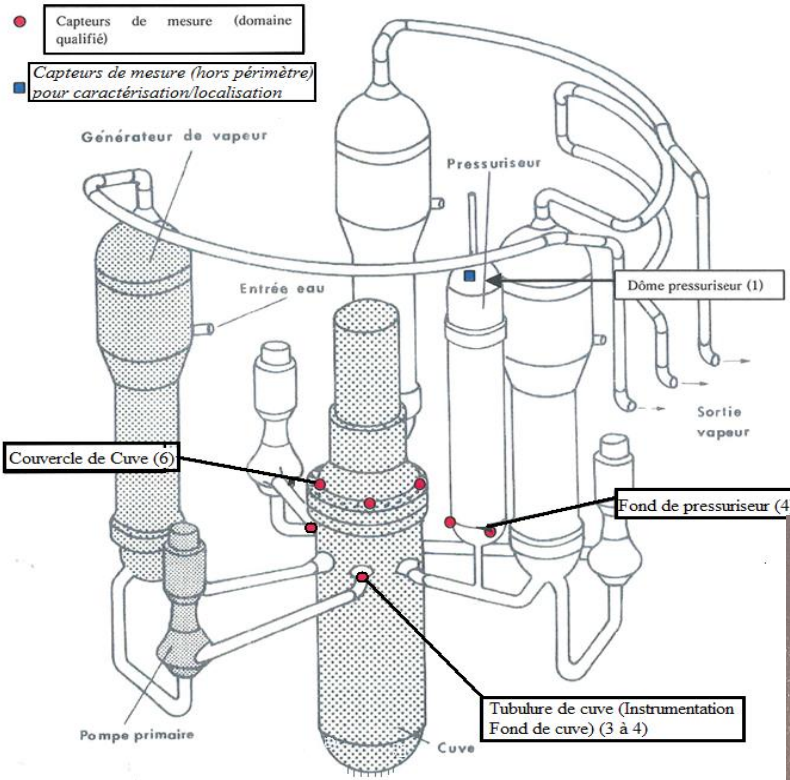

SUMMARY OF PRESENTATION

Part I: EDF at a glance

Part II: The EPR reactor and its scope of supply & opportunities

Part III: Localization & Qualification process

Part IV: PSI/ISI of the main welds of the EPR reactor

Part V: Conclusions

CONCLUSIONS

- ▶ During its construction and its 60 years of operation the EPR provides a wide scope of opportunities for local companies.
- ▶ The nuclear sector allows NDT vendors to reach the highest level of quality and safety standards
- ▶ The PSI/ISI program of the EPR Plant is covered in the RSE-M code:
 - ▶ Appendix 3.1.I (class 1 pressure components).
 - ▶ Linked with the chapter B4000 “Objectives and techniques examinations”.
 - ▶ In compliance with the French Nuclear Safety Regulations
 - ▶ A large part of the inspections are made with ultrasonic testing methods. This is made possible by the EPR design.

Over a 60 year period, a wide range of high added value operational activities, including NDT, will be created for the Polish industry